

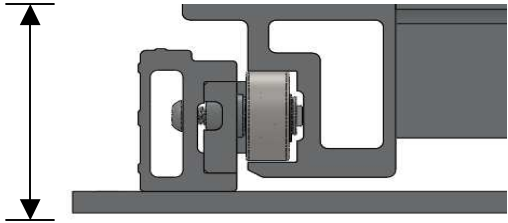

SlideMaster
Telescoping Cargo Handler

ALUMINUM 2-RAIL HEAVY DUTY

DECK HEIGHT 3-13/16"



END VIEW

*70% Extension
1,600 Lbs. Capacity*

*75% Extension
1,000 lbs. Capacity*

*80% Extension
600 lbs. Capacity*

SINGLE DIRECTION PRICING

<i>36-60"</i>	<i>61-72"</i>	<i>73-84"</i>	<i>85-96"</i>	<i>97-108"</i>	<i>109-120"</i>
\$636.00	\$683.00	\$736.00	\$784.00	\$847.00	\$912.00

DUAL DIRECTION PRICING

<i>36-60"</i>	<i>61-72"</i>	<i>73-84"</i>	<i>85-96"</i>	<i>97-108"</i>
\$721.00	\$768.00	\$821.00	\$869.00	\$932.00

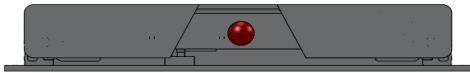

FRONT VIEW

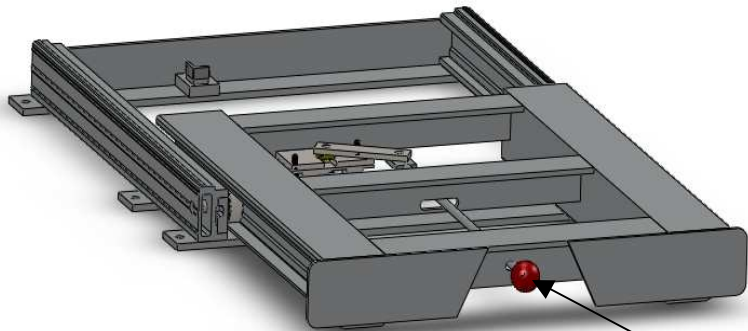

ORDERING INFORMATION:

AH - *Single Direction*

AHD - *Dual Direction*

AH

AHD

Extension - Length - Width

**Add \$30.00 for each 10" width exceeding 40"*

OPTIONS:

SL (Spring Lock) - *Only On AH - \$35.00*

INNOVATIVE INDUSTRIES INC.

1525 Deleglise Street

Antigo, WI 54409

Toll Free: 800-374-1134

Fax: 715-627-4528

Website: www.slide-master.com

***WEIGHT CAPACITY BASED ON UNIFORM DISTRIBUTION**